

CONFIGURATION BOM								
ITEM NO.	PART NO.	DESCRIPTION	881-A008-11-AB/QTY. (AUSGRID ITEM 18)	881-A008-11-AC/QTY. (AUSGRID ITEM 20)	881-A008-11-AD/QTY. (AUSGRID ITEM 23)	881-A008-11-AE/QTY. (AUSGRID ITEM 19)	881-A008-11-AF/QTY. (AUSGRID ITEM 21)	881-A008-11-AG/QTY. (AUSGRID ITEM 24)
1	007-7008N10	SURGE ARRESTOR LV 510V 5kA	3	3	3	3	3	3
2	061-7484-29	BUSBAR	1	1	1	1	1	1
3	061-7484-32	BUSBAR	3	3	3	3	3	3
4	061-7484-33	BUSBAR	1	1	1	1	1	1
5	123-7045-01	AUSGRID DM&C CONTROLL BOX - CUSTOMER SUPPLIED ITEM	1	1	1	1	1	1
6	123-7046-01	AUSGRID DM&C BATTERY BOX - CUSTOMER SUPPLIED ITEM	1	1	1	1	1	1
7	123-7047-01	AUSGRID DM&C ARIEL - CUSTOMER SUPPLIED ITEM	1	1	1	1	1	1
8	123-7050-01	DM&C MODULE ADDITIONAL I/O CARD - CUSTOMER SUPPLIED ITEM	-	-	-	1	-	-
9	133-A008-01	CONTROLL WIRING / CIRCUIT DIAGRAM	1	-	-	-	-	-
10	133-A008-02	CONTROLL WIRING / CIRCUIT DIAGRAM	-	1	-	-	-	-
11	133-A008-03	CONTROLL WIRING / CIRCUIT DIAGRAM	-	-	1	-	-	-
12	133-A008-04	CONTROLL WIRING / CIRCUIT DIAGRAM	-	-	-	1	-	-
13	133-A008-05	CONTROLL WIRING CIRCUIT DIAGRAM	-	-	-	-	1	-
14	133-A008-06	CONTROLL WIRING / CIRCUIT DIAGRAM	-	-	-	-	-	1
15	540-7000-05	CONTRACT - MRP ITEMS	1	1	1	1	1	1
16	665-7800-01	BATTERY BOX GLAND PLATE	1	1	1	1	1	1
17	787-7997-24	SWITCHGEAR SUPPORT	2	2	2	2	2	2
18	816-7646-02	SWITCHGEAR SCHNEIDER EZE102 - 1600A/4 WAY	1	-	-	-	-	-
19	816-7646-04	SWITCHGEAR SCHNEIDER EZE104 - 1600A/3 WAY	-	1	-	-	-	-
20	816-7646-06	SWITCHGEAR SCHNEIDER EZE106 - 1600A/2 WAY	-	-	1	-	-	-
21	816-7646-07	SWITCHGEAR SCHNEIDER EZE107 - 1600A/5 WAY	-	-	-	1	-	-
22	816-7646-08	SWITCHGEAR SCHNEIDER EZE108 - 1600A/4 WAY	-	-	-	-	1	-
23	816-7646-09	SWITCHGEAR SCHNEIDER EZE109 - 1600A/3 WAY	-	-	-	-	-	1
24	881-A008-12	KIOSK TRANSFORMER 800kVA - NO LV SWITCHGEAR	1	1	1	1	1	1

SUB ASSY BOM - 540-7000-05				
ITEM NO.	PART NUMBER	DESCRIPTION	LOCATION	QTY.
100	506-7006P13	LEAD EARTHING	LV SWITCHGEAR FRAME EARTH CABLE	2 EA

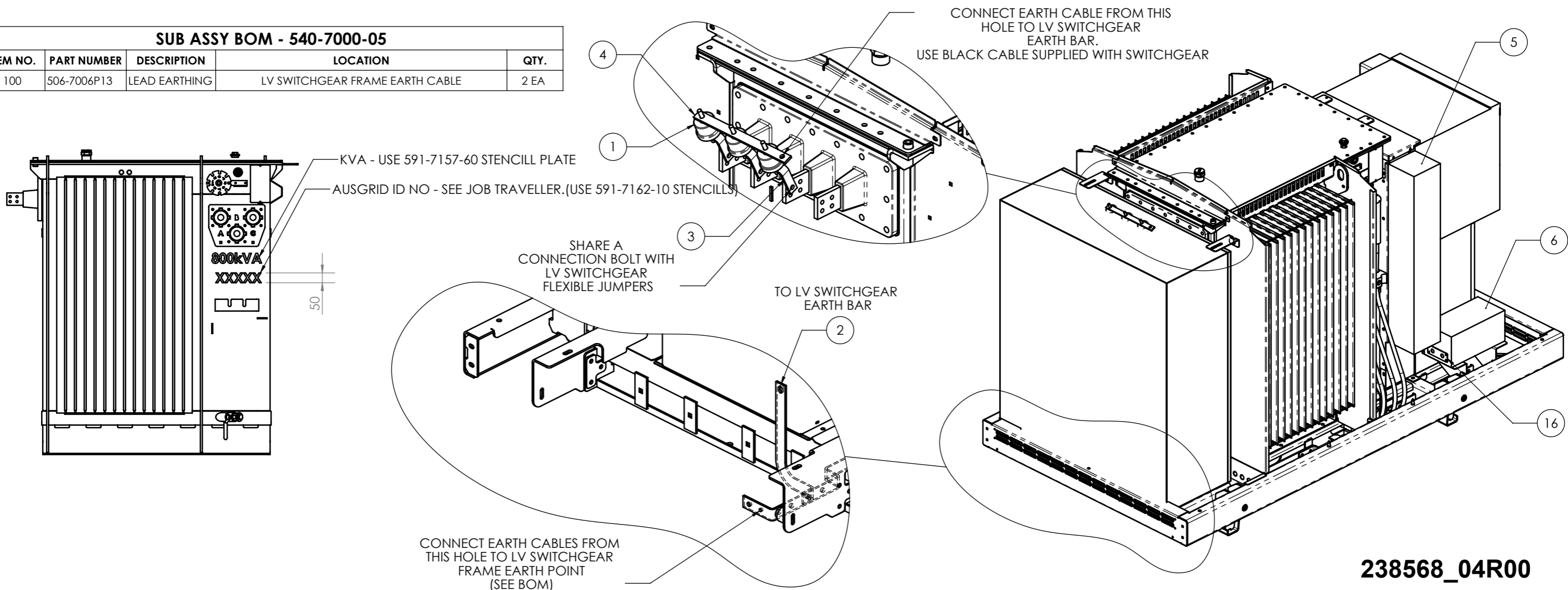

SHEET SIZE A3	All Welds to conform to AS 1554 sections 1 to 6, Cat.GP & 2B, unless specified otherwise. Min Weld Size Thickness of thinnest part Min.weld size ≤ 6mm > 6mm to 8 mm Thinnest mat. thickness > 10 mm > 10 mm 6 mm Butt weld DDT to be "Incomplete penetration butt weld" Thinnest mat. less 2 mm	TOLERANCE UNLESS OTHERWISE STATED LINEAR ANGULAR 1 ±1 (0-2000) 1 ±1° 1 ±3 (>2000) 1.0 ±1° 1.0 ±0.5 1.00 ±0.05° 1.00 ±0.05	WILSON TRANSFORMER CO. PTY. LTD. ACN 004 216 979	DESCRIPTION	FINISH: N/A REV U
				KIOSK TRANSFORMER 800kVA SCALE 1:20 PAGE 4 OF 4 FILE NO. 881-A008-11	
THIRD ANGLE PROJ.				ALL DIMENSIONS ARE IN mm UNLESS OTHERWISE STATED	