

REFERENCE DRAWING
MOULDED LINK-PANEL DRILLING DETAILS A2-38841

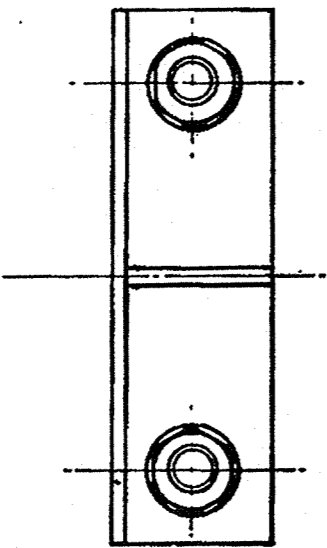

1	11	BOTTOM LINK PLATE	S.S. AISI 304	A3-50993
1	10	TOP LINK PLATE	S.S. AISI 304	A3-50993
6	9	M6 FLAT WASHER	S.S. AISI 304	
5	8	M6 SPRING WASHER	S.S. AISI 316	
9	7	M6 NUT	S.S. AISI 304	
1	6	LINK	S.S. AISI 304	A3-50993
1	5	LINK STUD	S.S. AISI 305	A3-50993
1	4	BOTTOM STUD	S.S. AISI 305	A3-50993
1	3	TOP STUD	SS. AISI 305	A3-50993
1	2	REAR PIECE	NYLON 66 (BLACK)	A3-50994
1	1	FRONT PIECE	NYLON 66 (BLACK)	A3-50994
ASSY. ITEM No.		DESCRIPTION	MATERIAL	REMARKS

AMENDMENT
H.O.B.-E.A.E.

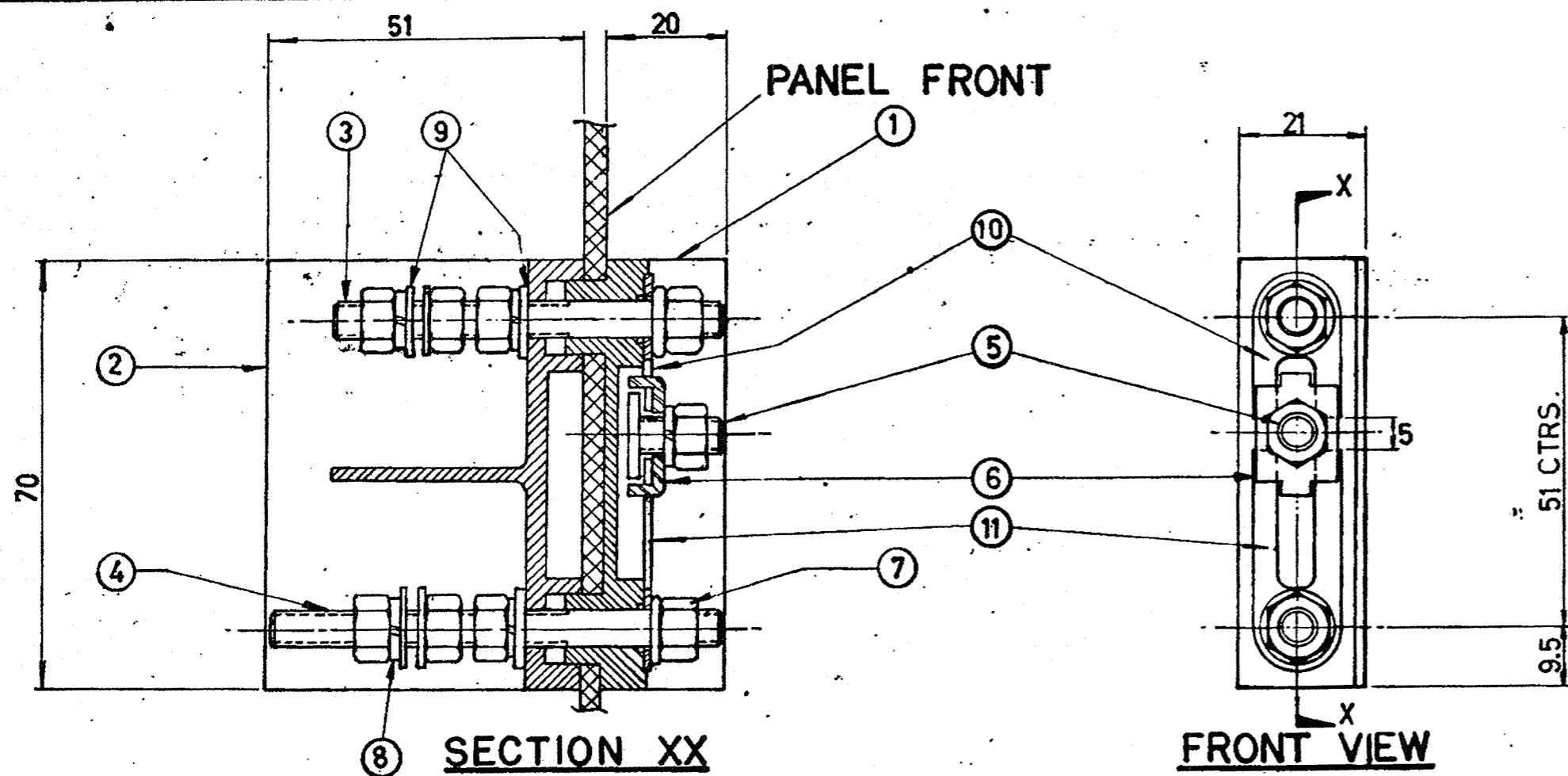

UNLESS OTHERWISE STATED ALL DIMENSIONS ARE IN mm

DRAWN	MCD/W.C.
DATE	15-11-74
SCALE	1:1
E.P.D.	<i>[Signature]</i>
Prof. E.	<i>[Signature]</i>

SUBSTATION
MOULDED TYPE LINK
ASSEMBLY

SCC THE SYDNEY COUNTY COUNCIL

SIZE	NUMBER	AMD.
A3	50992	