

A

B

C

D

E

F

A

B

C

D

E

F

**NOTES :**

1. THE FOLLOWING INFORMATION IS OBTAINED FROM THE PROJECT DESIGN DRAWINGS:
  - a. POLE LENGTH AND STRENGTH.
  - b. SPECIAL FOUNDATION REQUIREMENTS.
  - c. POLE EMBEDMENT DEPTH.
  - d. CONDUCTOR SIZE.
  - e. CROSSARM SIZE AND BRACE REQUIREMENTS.
  - f. STAY REQUIREMENTS.
  - g. DEVIATION ANGLE.
2. THE MAXIMUM LINE DEVIATION ANGLE TO BE CONSTRUCTED ON THIS ARRANGEMENT IS TO BE DETERMINED BY THE LINE DESIGNER.
3. POLE STEPS ARE TO BE INSTALLED IN ACCORDANCE WITH THE REQUIREMENTS OF NS128.
4. IN AREAS WHERE THE 11kV NETWORK CANNOT BE WORKED ON USING LIVE LINE TECHNIQUES, UNDERBUILT CIRCUITS SHALL BE INSTALLED WITH A MINIMUM CLEARANCE OF 1200mm. IN AREAS WHERE THE 11kV NETWORK CAN BE WORKED ON USING LIVE LINE TECHNIQUES, UNDERBUILT CIRCUITS SHALL BE INSTALLED WITH A MINIMUM CLEARANCE OF 2500mm.
5. ALL BOLTS AND INSULATOR PINS PASSING THROUGH TIMBER ARE TO BE COATED WITH GRAPHITE GREASE.
6. POLES SHALL BE DRILLED, SCARFED AND DRESSED ON SITE. DRILLING AND SCARFING TO BE TREATED WITH APPROVED PRESERVATIVES.
7. IF THE CONDUCTOR DEVIATES AT THE INSULATOR, USE THE ANGLE TYPE CONDUCTOR TIE ARRANGEMENT. OTHERWISE, USE THE INTERMEDIATE TYPE CONDUCTOR TIE ARRANGEMENT AS SHOWN ON DRG: 514038.
8. COMPOSITE FIBRE CROSSARMS ARE TO BE USED AS THE PREFERRED OPTION UNDER NORMAL CIRCUMSTANCES.
9. A 2706mm COMPOSITE FIBRE CROSSARM IS TO BE USED AS THE DEFAULT CROSSARM. A LONGER CROSSARM IS TO BE USED WHERE ADDITIONAL MID SPAN SEPARATION IS REQUIRED.
10. ONLY THE 2706mm COMPOSITE FIBRE CROSSARM OPTION IS SHOWN ON THIS CONSTRUCTION DRAWING. REFER TO DRGS: 262732 & 514373 FOR DRILLING PATTERN OF ALTERNATE CROSSARMS.
11. FOR DETAILS OF APPROVED ALTERNATE WAGNER COMPOSITE FIBRE CROSSARMS, REFER TO DRG: 265964.
12. REFER TO DESIGNER SAFETY REPORT D23/213473 FOR ATYPICAL HAZARDS ASSOCIATED WITH THIS STANDARD CONSTRUCTION.

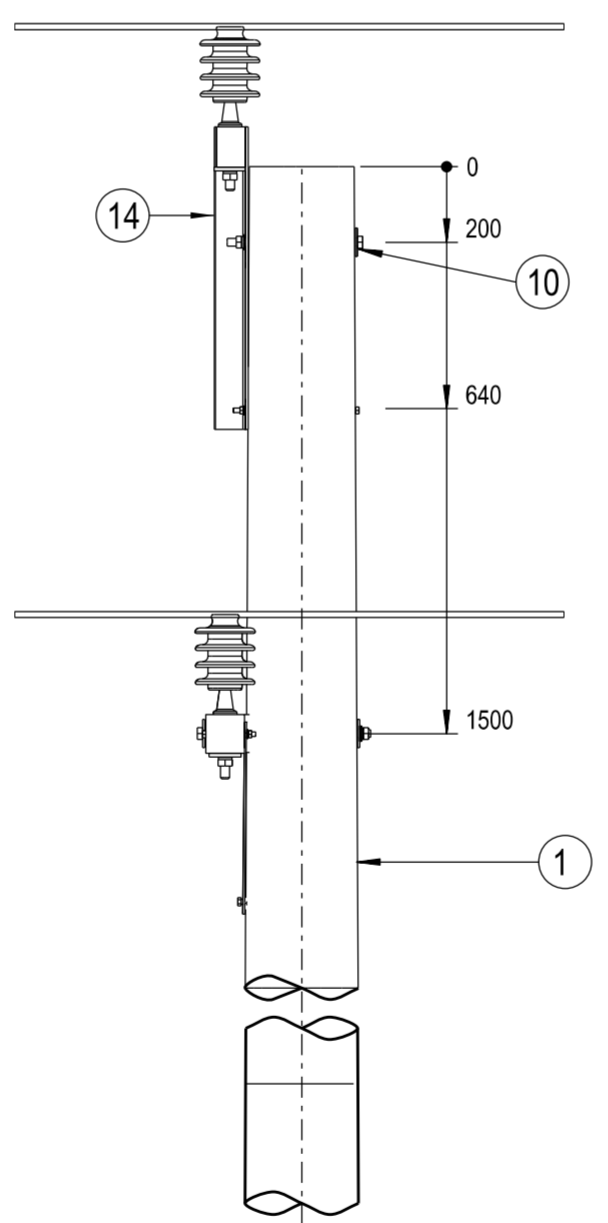
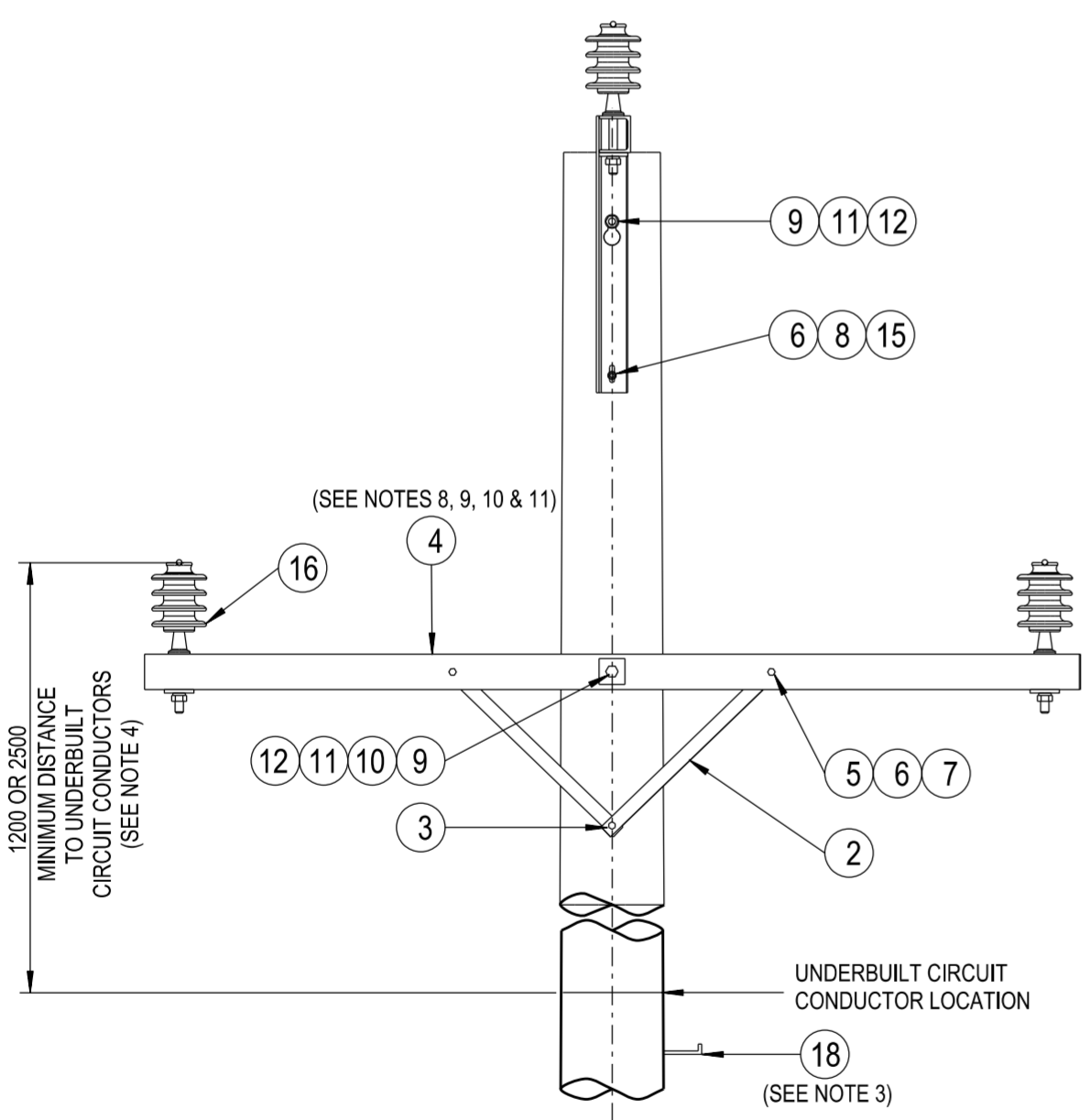
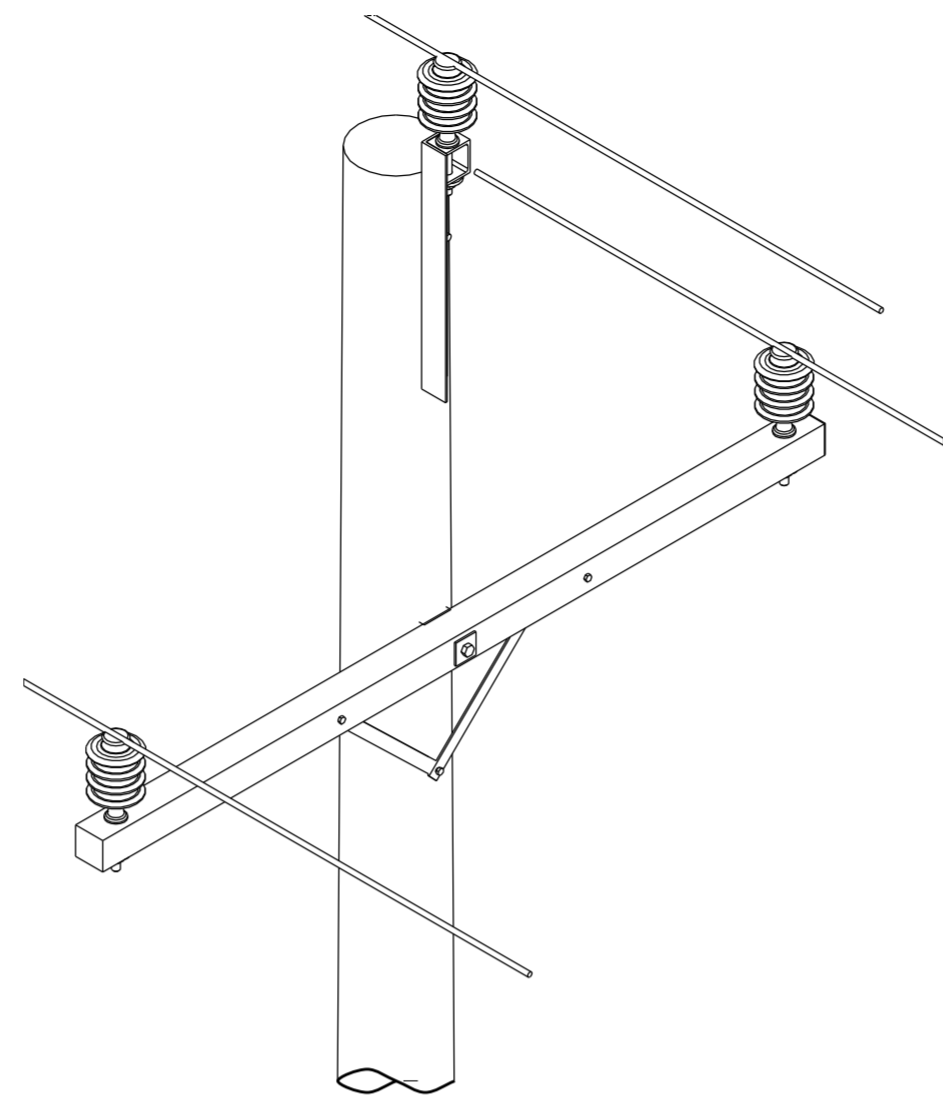
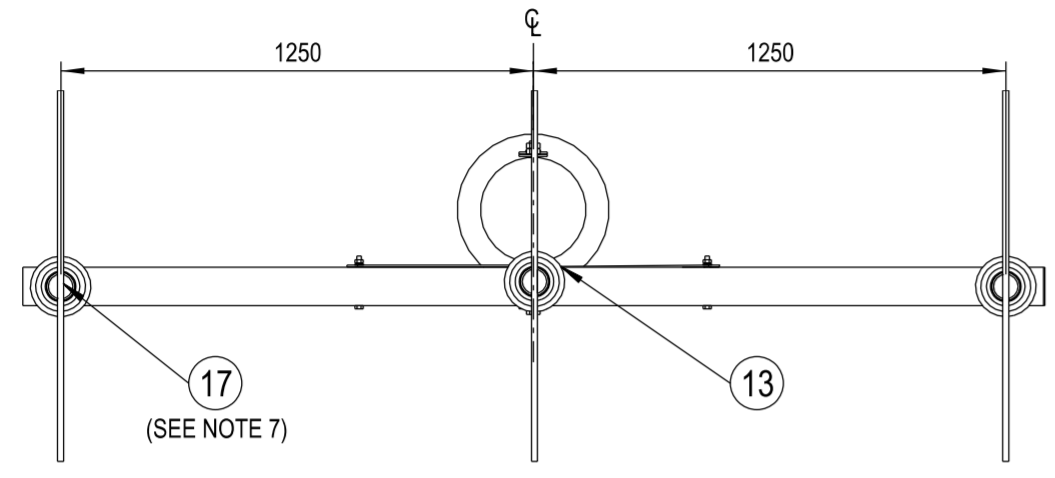

ITEM	DESCRIPTION	DRG. No	STOCK CODE	QTY
18	STEP - POLE, SCREW-IN (SEE NOTE 3)	250144	185198	A/R
17	TIE - CONDUCTOR, HIGH VOLTAGE, SUPPORT ARRANGEMENT (SEE NOTE 7)	514038		4m
16	INSULATOR - 11/22kV AERODYNAMIC, (22/450) & PIN ARRANGEMENT	513997		3
15	BOLT & NUT - M12, HEX., GALVANISED (LENGTH TO SUIT POLE)	515466		1
14	BRACKET - POLE TOP, GALVANISED	514380	H17314	1
13	BLOCK - GAIN, ALUMINIUM, 100mm		146274	1
12	WASHER - FLAT, M20, GALVANISED	518081	177986	2
11	WASHER - CONICAL, M20, GALVANISED	518082	H39655	2
10	WASHER - SQUARE, 75x75x6mm, GALVANISED (Ø22mm HOLE)	518081	H39231	3
9	BOLT & NUT - M20, HEX., GALVANISED (LENGTH TO SUIT POLE)	515466		2
8	WASHER - CONICAL, M12, GALVANISED	518082	H39639	1
7	WASHER - CONICAL, M12, GALVANISED (USE WITH HARDWOOD CROSSARM)	518082	H39639	2
	WASHER - SPRING, M12, GALVANISED (USE WITH COMPOSITE FIBRE CROSSARMS)	518082	H12047	
6	WASHER - FLAT, M12, GALVANISED	518081	177982	6
5	BOLT & NUT - M12x130mm, HEX., GALVANISED	515466	46805	2
	CROSSARM - 2700x100x100mm, TYPE B, HARDWOOD (SEE NOTES 8, 9, 10 & 11)	514373	H23884	
4	CROSSARM - 3006x102x102mm, TYPE 10, COMPOSITE FIBRE (SEE NOTES 8, 9, 10 & 11)	262732	186780	1
	CROSSARM - 2706x102x102mm, TYPE 9, COMPOSITE FIBRE (SEE NOTES 8, 9, 10 & 11)	262732	186779	
3	SCREW - COACH, M12x100mm, GALVANISED		H40484	1
2	BRACE - CROSSARM, FLAT, 690mm, GALVANISED	514385	H17738	2
1	POLE - TIMBER (AS REQUIRED)	513988		1

ALL DIMENSIONS IN MILLIMETRES UNLESS NOTED OTHERWISE. DO NOT SCALE.

CAD DRAWING DO NOT MANUALLY AMEND A M E N D M E N T S	DATE: 25/09/2024 NOTES & MATERIAL LIST AMENDED. ASSOCIATED DRAWING ADDED.
DWN: P.R.	DWN: P.R.
CHKD: P.J.	CHKD: P.J.
APPD: G.F.	APPD: G.F.
DATE: 25/09/2024 WAGNER CROSSARM OPTION REMOVED FROM MATERIAL LIST. NOTE ADDED.	

DESCRIPTION	QTY
COMPOSITE FIBRE CROSSARMS WAGNER SPECIFICATION	265964
2700mm CROSSARMS FOR LV, 11kV, 22kV AND 33kV CONSTRUCTION DETAILS	514373
COMPOSITE FIBRE CROSSARMS SPECIFICATION	262732
HV CONDUCTOR TIE SUPPORT ARRANGEMENTS	514038

NETWORK STANDARD  
**Ausgrid**  
145 NEWCASTLE RD WALLSEND,  
NSW 2287

SCALE	1:20	STANDARD CONSTRUCTION		
DESIGNED	-	11kV LARGE DELTA CONSTRUCTION		
DRAWN	PETER SAUNDERS	2-7		
CHECKED	P.A.S			
APPROVED	G.SKINNER			
DATE	12/06/1996			
PROJECT NUMBER	STD			
PROJTRAK NUMBER	-	SIZE	DRAWING No	SHEET
		A2	513913	1
				AMD
				13