

A

B

C

D

E

F

A

B

C

D

E

F

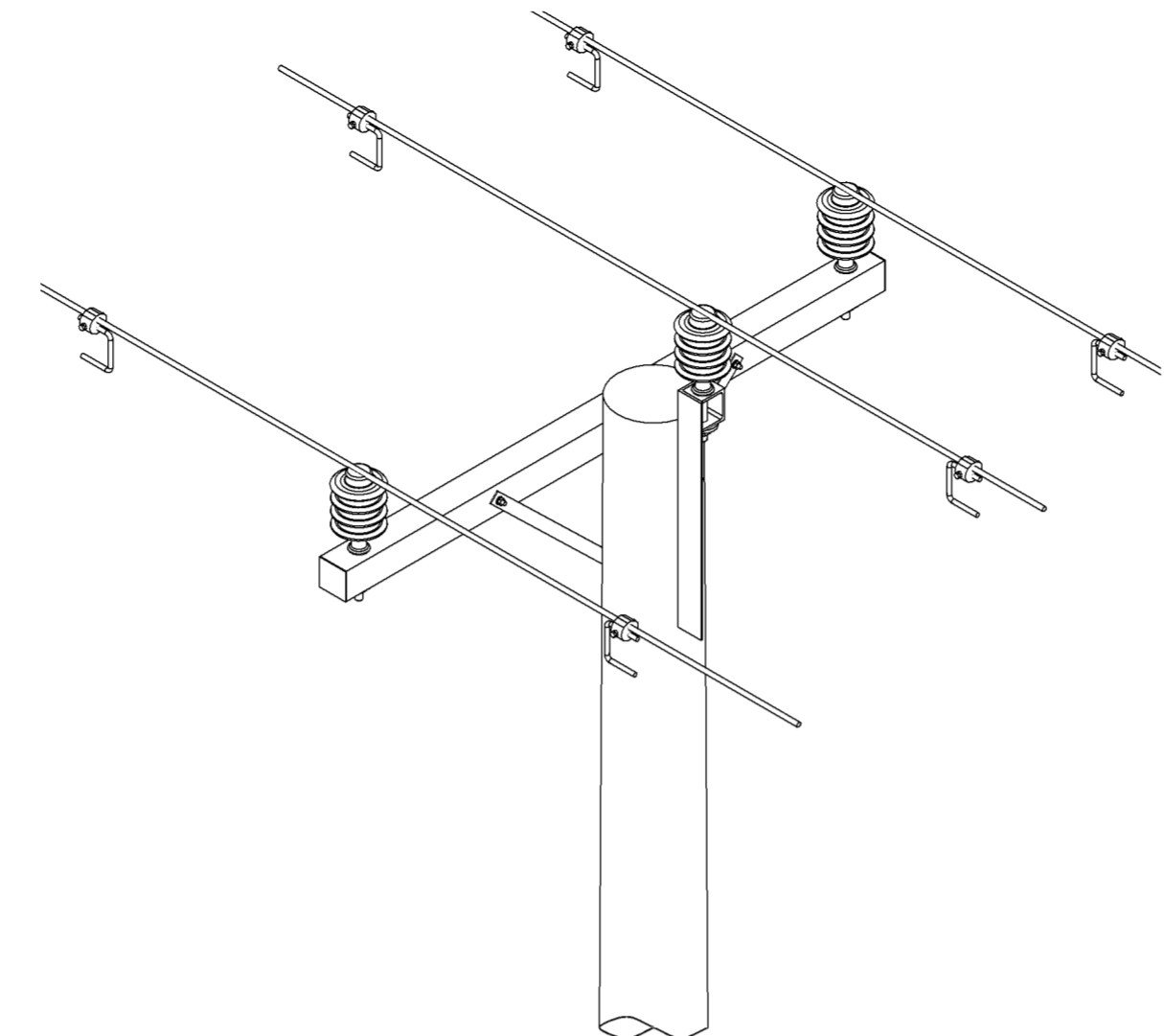
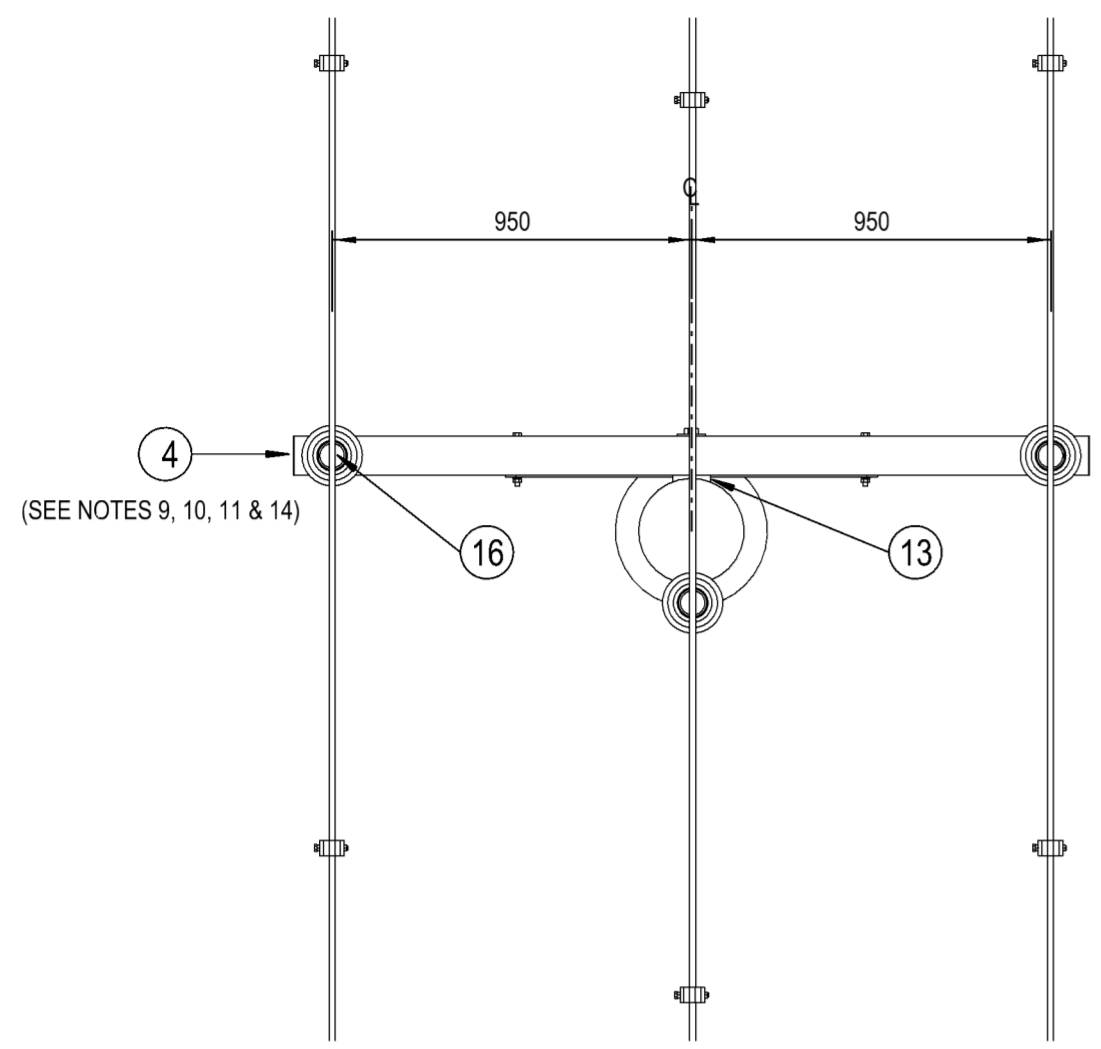

NOTES :

1. THE FOLLOWING INFORMATION IS OBTAINED FROM THE PROJECT DESIGN DRAWINGS:
 - a. POLE LENGTH AND STRENGTH.
 - b. SPECIAL FOUNDATION REQUIREMENTS.
 - c. POLE EMBEDMENT DEPTH.
 - d. CONDUCTOR SIZE.
 - e. CROSSARM SIZE AND BRACE REQUIREMENTS.
 - f. STAY REQUIREMENTS.
 - g. DEVIATION ANGLE.
2. THE MAXIMUM LINE DEVIATION ANGLE TO BE CONSTRUCTED ON THIS ARRANGEMENT IS TO BE DETERMINED BY THE LINE DESIGNER.
3. POLE STEPS ARE TO BE INSTALLED IN ACCORDANCE WITH THE REQUIREMENTS OF NS128.
4. IN AREAS WHERE THE 11kV NETWORK CANNOT BE WORKED ON USING LIVE LINE TECHNIQUES, UNDERBUILT CIRCUITS SHALL BE INSTALLED WITH A MINIMUM CLEARANCE OF 1200mm. IN AREAS WHERE THE 11kV NETWORK CAN BE WORKED ON USING LIVE LINE TECHNIQUES, UNDERBUILT CIRCUITS SHALL BE INSTALLED WITH A MINIMUM CLEARANCE OF 2500mm.
5. ALL BOLTS AND INSULATOR PINS PASSING THROUGH TIMBER ARE TO BE COATED WITH GRAPHITE GREASE.
6. POLES SHALL BE DRILLED, SCARFED AND DRESSED ON SITE. DRILLING AND SCARFING TO BE TREATED WITH APPROVED PRESERVATIVES.
7. TO MAINTAIN THE INTEGRITY OF A COVERED SYSTEM, IT IS ESSENTIAL THAT ALL STRIPPED AND PUNCTURED INSULATION IS CONTAINED WITHIN THE APPROPRIATE INSULATING COVER.
8. SURGE ARRESTERS ARE TO BE INSTALLED ON AN OVERHEAD CCSX CONDUCTOR SYSTEM IN ACCORDANCE WITH THE REQUIREMENTS OF NS126. IF A SURGE ARRESTER IS TO BE INSTALLED ON THIS CONSTRUCTION, IT IS TO BE INSTALLED AS PER THE RELEVANT COVERED CONDUCTOR ARRANGEMENT SPECIFIED IN DRG: 265905.
9. COMPOSITE FIBRE CROSSARMS ARE TO BE USED AS THE PREFERRED OPTION UNDER NORMAL CIRCUMSTANCES.
10. A 2106mm COMPOSITE FIBRE CROSSARM IS TO BE USED AS THE DEFAULT CROSSARM. A LONGER CROSSARM MAY BE CONSIDERED TO OVERCOME DESIGN AND SITE REQUIREMENTS.
11. ONLY THE 2106mm COMPOSITE FIBRE CROSSARM OPTION IS SHOWN ON THIS CONSTRUCTION DRAWING. REFER TO DRGS 262732, 514374 & 15232 FOR DRILLING PATTERN OF ALTERNATE CROSSARMS.
12. THE 690mm CROSSARM BRACES ARE TO BE USED ON A 2106mm & 2100mm CROSSARM. THE 740mm CROSSARM BRACE IS TO BE USED ON A 2406 & 2400mm CROSSARM.
13. A CCSX EARTHING POINT IS TO BE INSTALLED WHERE REQUIRED FOR OPERATIONAL PURPOSES OR AT LOCATIONS SPECIFIED IN NS126. ONLY ONE SET OF EARTHING POINTS IS REQUIRED ON THIS CONSTRUCTION. THE EARTHING POINTS CAN BE INSTALLED AT EITHER OF THE ALTERNATE LOCATIONS INDICATED.
14. FOR DETAILS OF APPROVED ALTERNATE WAGNER COMPOSITE FIBRE CROSSARMS, REFER TO DRG: 265964.
15. REFER TO DESIGNER SAFETY REPORT D24/81955 FOR ATYPICAL HAZARDS ASSOCIATED WITH THIS STANDARD CONSTRUCTION.

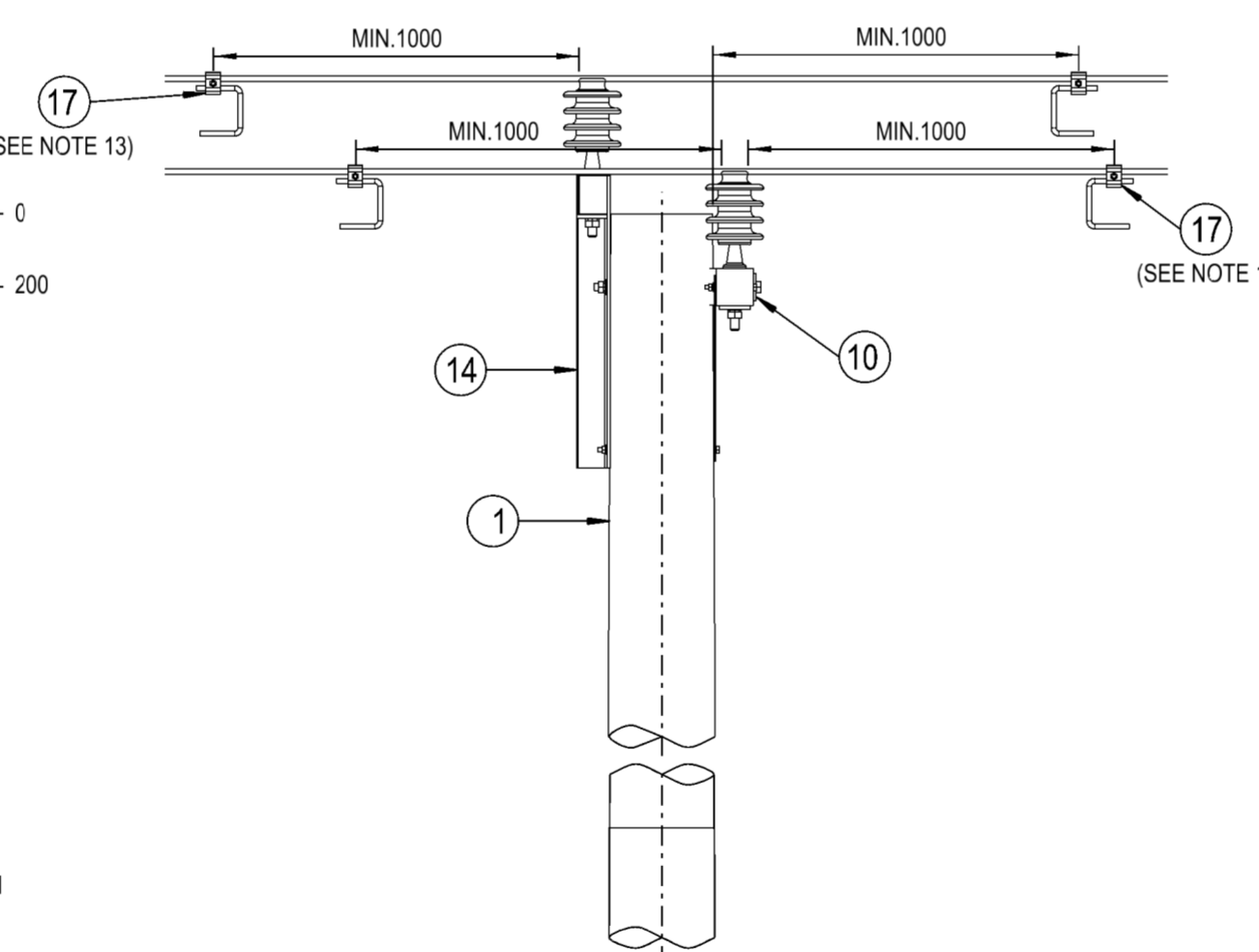
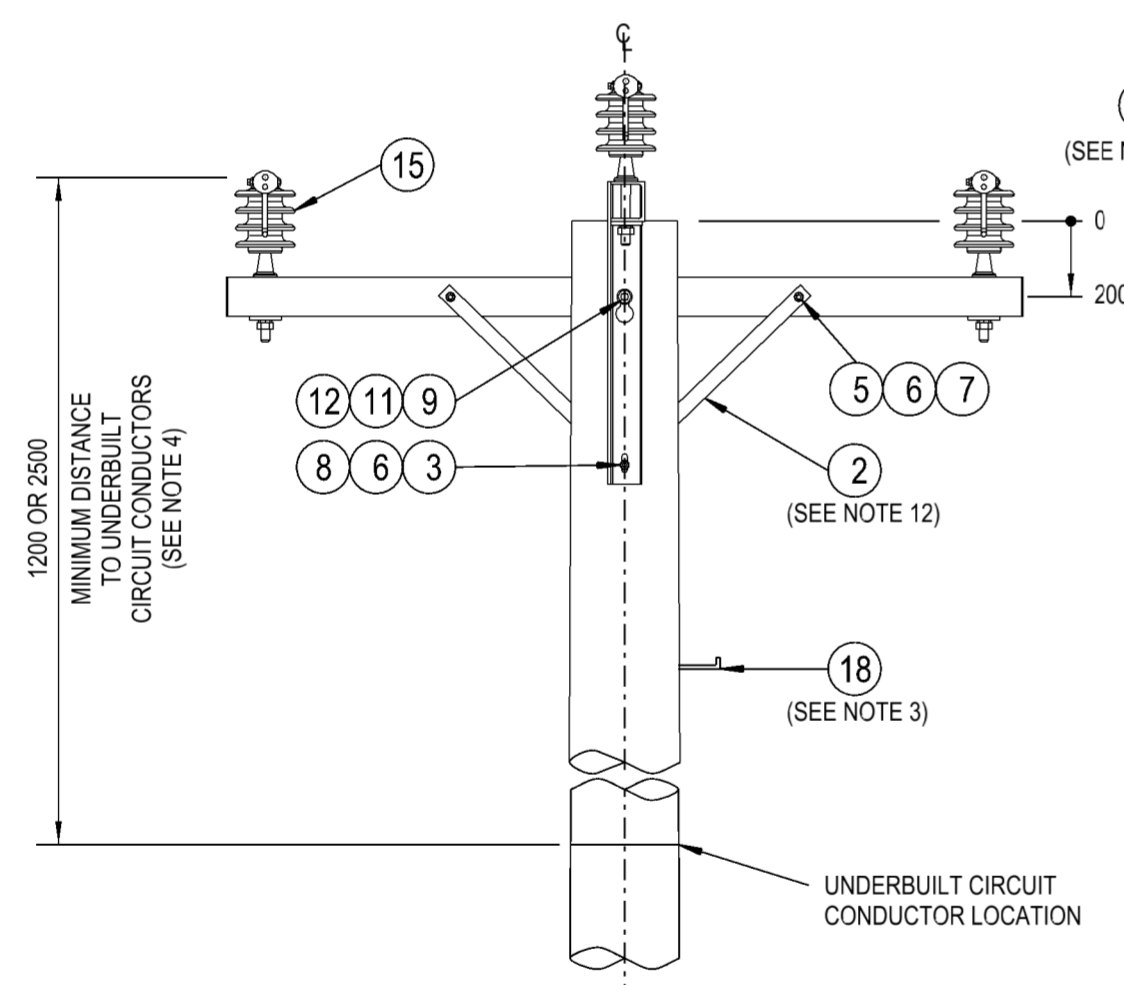

ITEM	DESCRIPTION	DRG. No	STOCK CODE	QTY
18	STEP - POLE, SCREW-IN (SEE NOTE 3)	250144	185198	A/R
17	EARTH - PARKING, DEVICE, IPC CC TO EPD (ENSTO REF. SLW26.A2) (SEE NOTE 13)		186865	3
16	WIRE - TIE, PREFORMED, INSULATED, FOR CCSX159 (SET OF 6) (ENSTO REF. SO216.157)		186874	1
	WIRE - TIE, PREFORMED, INSULATED, FOR CCSX62 (SET OF 6) (ENSTO REF. SO216.62)		186875	
	WIRE - TIE, PREFORMED, INSULATED, FOR CCSX25 (SET OF 6) (ENSTO REF. SO216.25)		186876	
15	INSULATOR - 11/22kV AERODYNAMIC, (22/450) AND PIN ARRANGEMENT	513997		3
14	BRACKET - POLE TOP, GALVANISED	514380	H17314	1
13	BLOCK - GAIN, ALUMINIUM, 100mm		146274	1
12	WASHER - FLAT, M20, GALVANISED	518081	177986	1
11	WASHER - CONICAL, M20, GALVANISED	518082	H39655	1
10	WASHER - SQUARE, 75x75x6mm, GALVANISED (Ø22mm HOLE)	518081	H39231	1
9	BOLT & NUT - M20, HEX., GALVANISED (LENGTH TO SUIT POLE)	515466		1
8	WASHER - CONICAL, M12, GALVANISED	518082	H39639	1
7	WASHER - CONICAL, M12, GALVANISED (USE WITH 2400mm CROSSARM)	518082	H39639	1
	WASHER - CONICAL, M12, GALVANISED (USE WITH 2100mm CROSSARM)	518082	H39639	2
	WASHER - SPRING, M12, GALVANISED (USE WITH 2406mm CROSSARM)	518082	H12047	1
	WASHER - SPRING, M12, GALVANISED (USE WITH 2106mm CROSSARM)	518082	H12047	2
6	WASHER - FLAT, M12, GALVANISED (USE WITH 2406mm & 2400mm CROSSARMS)	518081	177982	3
	WASHER - FLAT, M12, GALVANISED (USE WITH 2106mm & 2100mm CROSSARMS)	518081	177982	5
5	BOLT & NUT - M12x130mm, HEX., GALVANISED (USE WITH 2406mm & 2400mm CROSSARMS)	515466	46805	1
	BOLT & NUT - M12x130mm, HEX., GALVANISED (USE WITH 2106mm & 2100mm CROSSARMS)	515466	46805	2
4	CROSSARM - 2400x100x100mm, TYPE H1, HARDWOOD (SEE NOTE 9, 10, 11 & 14)	15232	71928	1
	CROSSARM - 2100x100x100mm, TYPE C, HARDWOOD (SEE NOTE 9, 10, 11 & 14)	514374	H23834	
	CROSSARM - 2406x102x102mm, TYPE 8, COMPOSITE FIBRE (SEE NOTE 9, 10, 11 & 14)	262732	186778	
3	CROSSARM - 2106x102x102mm, TYPE 7, COMPOSITE FIBRE (SEE NOTE 9, 10, 11 & 14)	262732	186777	1
	BOLT & NUT - M12, HEX., GALVANISED (LENGTH TO SUIT POLE)	515466		
2	BRACE - CROSSARM, ANGLE, TYPE H, 740mm, GALVANISED (SEE NOTE 12)	46	99119	1
	BRACE - CROSSARM, FLAT, 690mm, GALVANISED (SEE NOTE 12)	514385	H17738	2
1	POLE - TIMBER (AS REQUIRED)	513988		1

ALL DIMENSIONS IN MILLIMETRES UNLESS NOTED OTHERWISE. DO NOT SCALE.

CAD DRAWING DO NOT MANUALLY AMEND AMENDMENTS	
DWN: P.R.	
CHKD: P.J.	
APPD: G.F.	
DATE: 25/09/2024	
ITEM 17 ADDED. MATERIAL LIST & NOTES AMENDED.	
DWN: P.R.	
CHKD: P.J.	
APPD: G.F.	
DATE: 25/09/2024	
MATERIAL LIST AMENDED. WAGNER CROSSARM NOTE ADDED.	

DESCRIPTION	DRG. No
COMPOSITE FIBRE CROSSARMS WAGNER SPECIFICATION	265964
11kV CCSX CONDUCTOR SURGE ARRESTER ARRANGEMENTS	265905
WOODEN CROSSARMS FOR 11kV LINES	15232
2100mm CROSSARMS FOR LV, 11kV AND 33kV CONSTRUCTION DETAILS	514374
COMPOSITE FIBRE CROSSARMS SPECIFICATION	262732

NETWORK STANDARD

145 NEWCASTLE RD WALLSEND, NSW 2287

SCALE	1:20	STANDARD CONSTRUCTION 11kV SMALL DELTA CONSTRUCTION 2-5CCSX
DESIGNED	J.BROOKS	
DRAWN	P.RIOS	
CHECKED	P.JONES	
APPROVED	G.FORD	
DATE	28/03/2024	
PROJECT NUMBER	STD	
PROJ/TRAK NUMBER	-	

SIZE	DRAWING No	SHEET	AMD
A2	265888	1	2